

# Amoré Bay

*The Bay Collection*



M-Drive



LiquidFX



UltraPure Plus



Massage Sequencer



2 UltraLounges



2 NeckFlex Pillows

## Shell Colors



UltraLife Jasper Obsidian Opal Graphite



Tanzanite Moonstone Sunstone Sand

## Architectural Trim

ENVIROTECT



Tan Brown Gray



Oak Cherry Cattails

## Specifications

Dimensions **108" L x 92" W x 40" H**

Seating **7**

Jets **62 jets**

Electrical **240V, 40/50A**

NeckFlex Jet Pillows **2**

Water Management **UltraPure Plus**

Full-Foam Insulation **Standard**

Liquid FX **Standard**

Stereo **Optional**

## Features



5 Pumps



7 Persons



62 Jets



2 NeckFlex Jet Pillows



2 UltraLounges



UltraPure Plus



M-Drive



Liquid FX



DIMENSION ONE SPAS®

www.d1spas.com

General	
Shape	Free form / Rectangle
Seating Capacity	7
Shell Material	Ultralife™ / Geloy®
Dimensions	108" x 92" x 40" H / (275cm X 234cm x 102cm H)
Corner Radii	N/A
Water Capacity	415 Gallons (1571 Liters)
Dry Weight	1011lbs (459 kg)
Shipping Weight	Domestic 1011 lbs (459 kg) - Export 1061 lbs (481 kg)
Full Weight	4467 lbs (2026 kg)
Skirt Material	Synthetic
Poly Floor	Yes

Water System	
Water Treatment System	UltraPure® Plus
Plumbing Systems	5
Filters/Coverage	2 / 75 sq. ft.
Gate Valves	6
VCR Jet® - Air Adjustable/Directional	2
VCR Jet® - Directional	1
VCR Jet® - Rotator	2
VCR Jet® - Dual Rotator	4
VCR Jet® - Multi Port Spinner	2
VCR Jet® - Mini Rotator	22
VCR Jet® - Mini Directional	10
VCR Jet® - Euro Directional	2
VCR Jet® - Euro Rotator	8
VCR Jet® - Mini Directional in NFJ	8
Typhoon Jet	1
Ozone Jet	1
Heater Return Jet	1
Pump Returns	6
Diverter Valves	2
Floor Drains	1
Skimmer	8" Weir

Special Features	
Dynamic Massage Sequencer w/ control panel	Yes
NeckFlex® Jet Pillows	2
Bartop Lighting	Yes
Stereo system	Optional Poly-Planar
Water Feature	Yes
Water Feature Volume control	Yes
Cup Holders	2
Tactile Therapy	Floor pedestal / Arms
Under water magnetic switch	Yes
Fountain Diverter	Yes

Pump Information	Domestic (60Hz)	Export (50Hz)
Motor Size – Peak (Continuous) HP	3.6 (2.0) HP	3.6 (2.0) HP
Jet Pumps # of Pumps/Speed	One / Dual & Two / Single	One / Dual & Two / Single
Circulation pump	1	1
Fountain pump	1	1
Electrical System	Domestic (60Hz)	Export (50Hz)
Voltage	240	240
Amperage	50/40	2X16 / 1X32   3X16
Heater	FastFlo 2.7,4.0,5.5 kW	FastFlo 3.3 kW   2.1, 5.2 kW
Thermostat	Electronic	Electronic
Light	Multi color LED	Multi color LED
Control System	MSPA-MP-D16	MSPA-MP-D14-CE
Upper Control (programmable)	M-Drive with Scrolling Message Center	M-Drive with Scrolling Message Center
Auxiliary Upper Control	No	No



Note: 1. Subject to change without notice.

# Amore Bay Architectural Specification

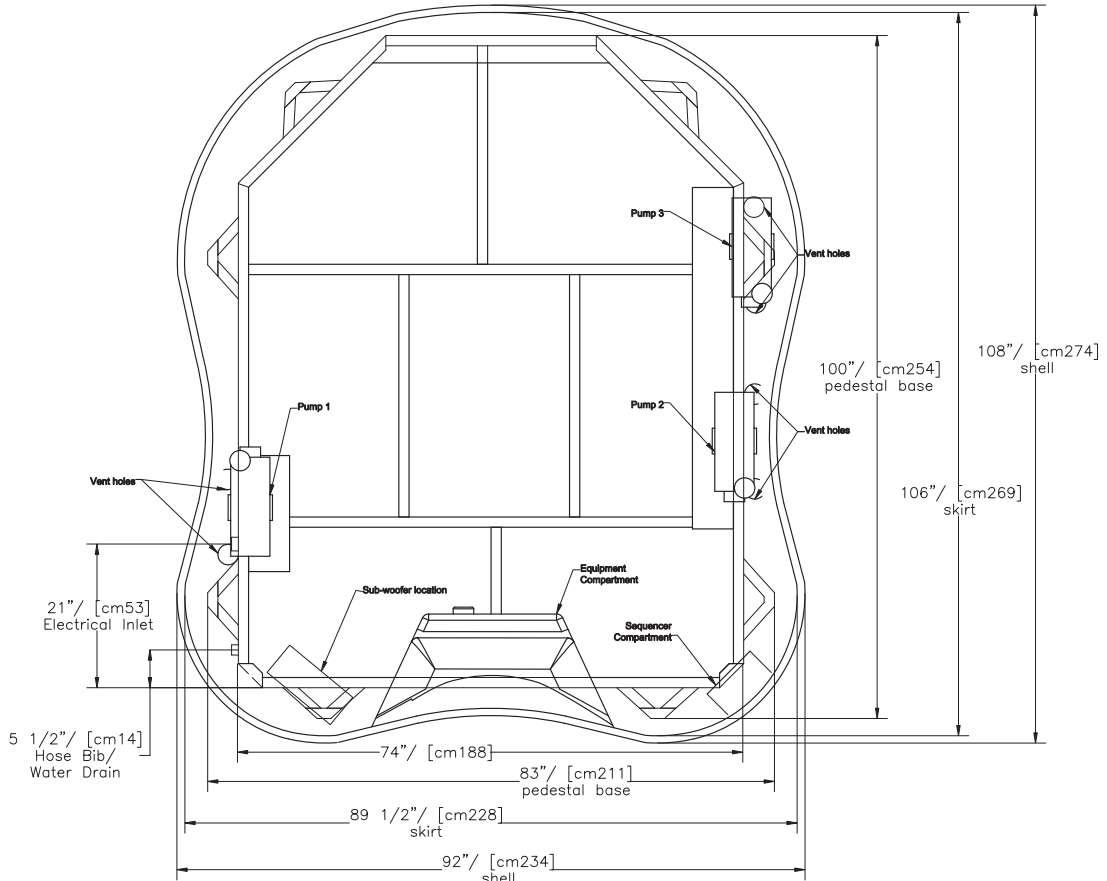

Top View Of Spa

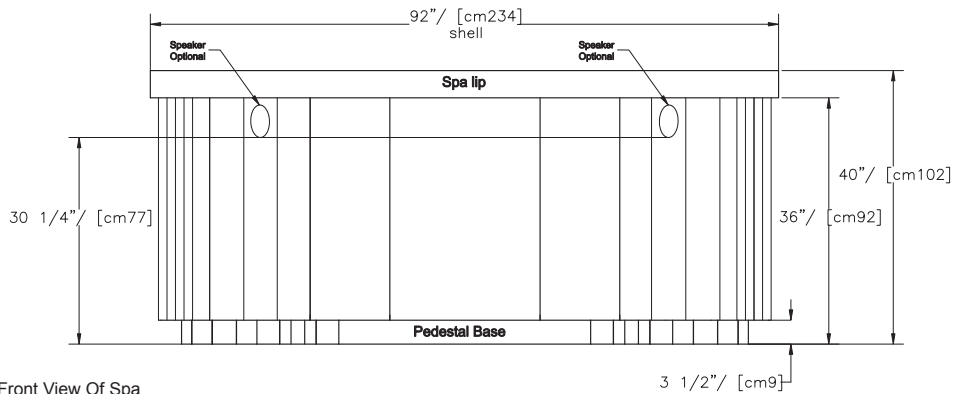

Front View Of Spa

**Caution:**  
 Due to manufacturing tolerances there could be some minor differences between the actual spa and the drawing above. If site planning is critical to such tolerances, be sure to measure your actual spa.

- Note:**
1. Subject to change without notice.
  2. Engineering specs may differ slightly from brochure.
  3. For E-Z lifter installation allow 18" (45.72cm) clearances on the backside of the spa.
  4. Alternative cabinets may add significant weight. Ask your dealer for exact details

Dimensions shown as inches and (centimeters) -XX" (cm)